

EAGLE DISTRICT CUBMOBILE RACE



2010 Rules & Registration

Race Day Information:

Date: May 15, 2010
Time: Race starts 10:00 AM. Registration is open 9:00-10:00 AM for the competition.
Cost: FREE
Location: Main Street, Luther, Oklahoma
Contact: Suzy Koch (“Cook”) 405-570-1717
Map:

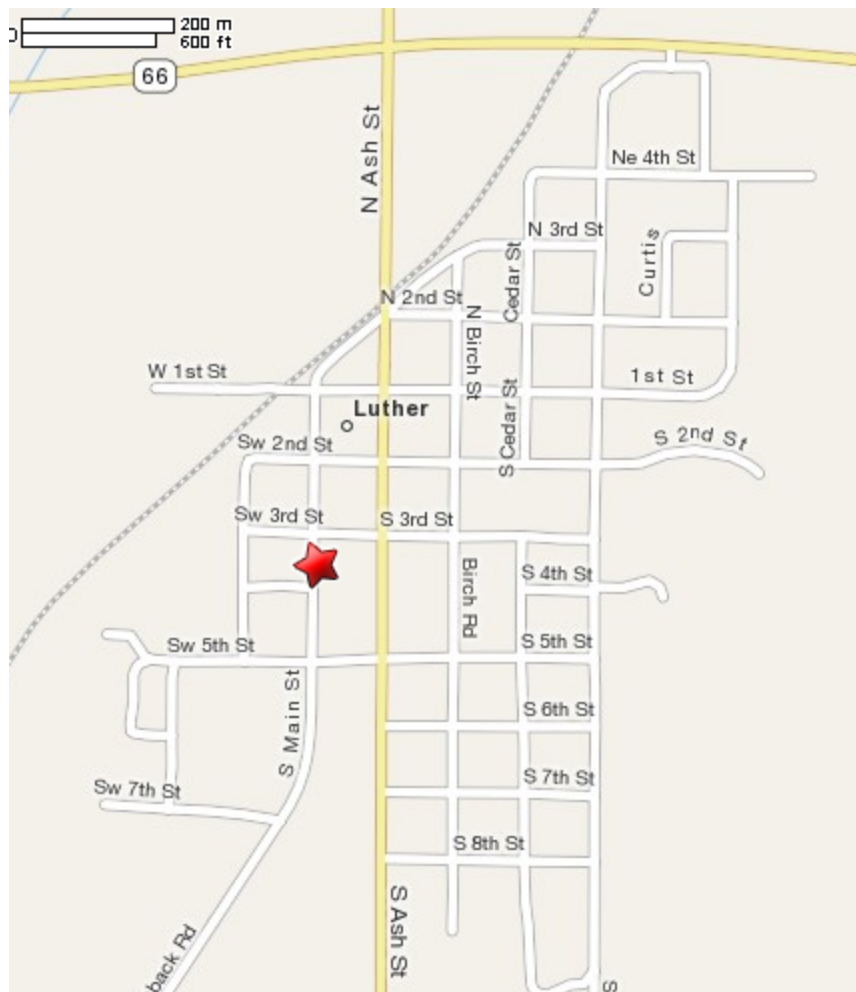

Directions:

Take Route 66 (Second Street, Edmond) East from I-35 for 13 miles to Luther Road (which is Ash St. on the map). Turn Right (South) on Luther Rd.. At Railroad Tracks, Main Street is on the right. Main street will be blocked off for the cubmobile event. Follow the signs for parking.

Luther is welcoming scouts from all over Eagle District. We would like to make a great showing for this fun event. Local groups will be selling hot dogs for lunch.

General information:

Cubmobile racers are much like soapbox racers in that they roll downhill powered only by gravity. Specific instructions for construction of a cubmobile follow below. In the Eagle District event, cars will go down two at a time, for at least four runs each, along a straight course, having been released initially down a short ramp. All runs will be timed and the fastest three times for each car will be averaged to determine awards. Some design awards will also be given.

STARTING THIS YEAR we are scoring the driver times and not those of the car. Each driver gets four races. The car is not limited in the number of races, thus multiple drivers can use the same car. For example, if a den has eight boys and wants to build three racers for all of the boys to take turns racing, that would be excellent. We want to encourage participation and make this a popular yearly event for the entire district. Please be reasonable. Two or three scouts per car should be the maximum because the wait time for cars to return to start is a factor when too many scouts share too few cars.



Rules for Construction:

- ✦ 1. NO CONNECTIONS MAY BE SECURED WITH NAILS! Fasteners must be bolts (with caps), lag screws, screws, or wood screws. (A small number of well-driven nails may be permitted for attaching decorations, etc., however.)
- ✦ 2. The car's frame must be MADE FROM 2X4 LUMBER AND FOLLOW THE DIMENSIONS OF THE ATTACHED DIAGRAM. Beams must be structurally sound and have NO SPLINTERS! The backrest must be braced.
- ✦ 3. NO ROPE STEERING! Drivers must steer with their feet. (This rule differs from cubmobile rules in some other races.)
- ✦ 4. THE CAR MUST HAVE A SEAT BELT of some type to protect the driver from injury if a sudden stop occurs and this belt must be at least 1/2" wide (to avoid undue abdominal local pressure). Thick rope seat belts are permitted.
- ✦ 5. THE DRIVER MUST HAVE A PROTECTIVE HELMET (e.g. bike, skating or football), AND CLOSED-TOE SHOES!
- ✦ 6. THE BRAKE MUST BE BOLT-MOUNTED AND THE CONTACT SURFACE MUST BE COVERED WITH RUBBER OR A SIMILAR SUBSTANCE that will rapidly retard motion. The brake should descend at the rear (as in the diagram) rather than the front, so that the car does not pop off the ground.
- ✦ 7. THE WHEEL DIAMETER MUST BE 5 TO 10 INCHES AND EACH WHEEL MUST BE ATTACHED TO ITS AXLE WITH A BOLT. No axles with pins are allowed. Wheels may have bearings if desired. All wheels must have SOLID RUBBER TIRES - no inflated tires are allowed.
- ✦ 9. The steering axle bolt must be double-nutted or bear a lock nut.
- ✦ 10. Steering blocks must be no more than 1/2" inch from the main frame (with no more than 1/8" recommended since the course is straight). Many drivers cars whose gap is 1/4" or more will have difficulty staying on the course and will run into a curb.
- ✦ 11. NO EXTRA WEIGHT IS ALLOWED. Securely attached lightweight objects (including wood) that do not raise safety concerns such as impaling are allowed for decorative purposes, however.
- ✦ 12. Axle lubricants are permitted but must not stain the pavement.
- ✦ 13. Any writing and/or pictures on the car must be consistent with B.S.A. values.

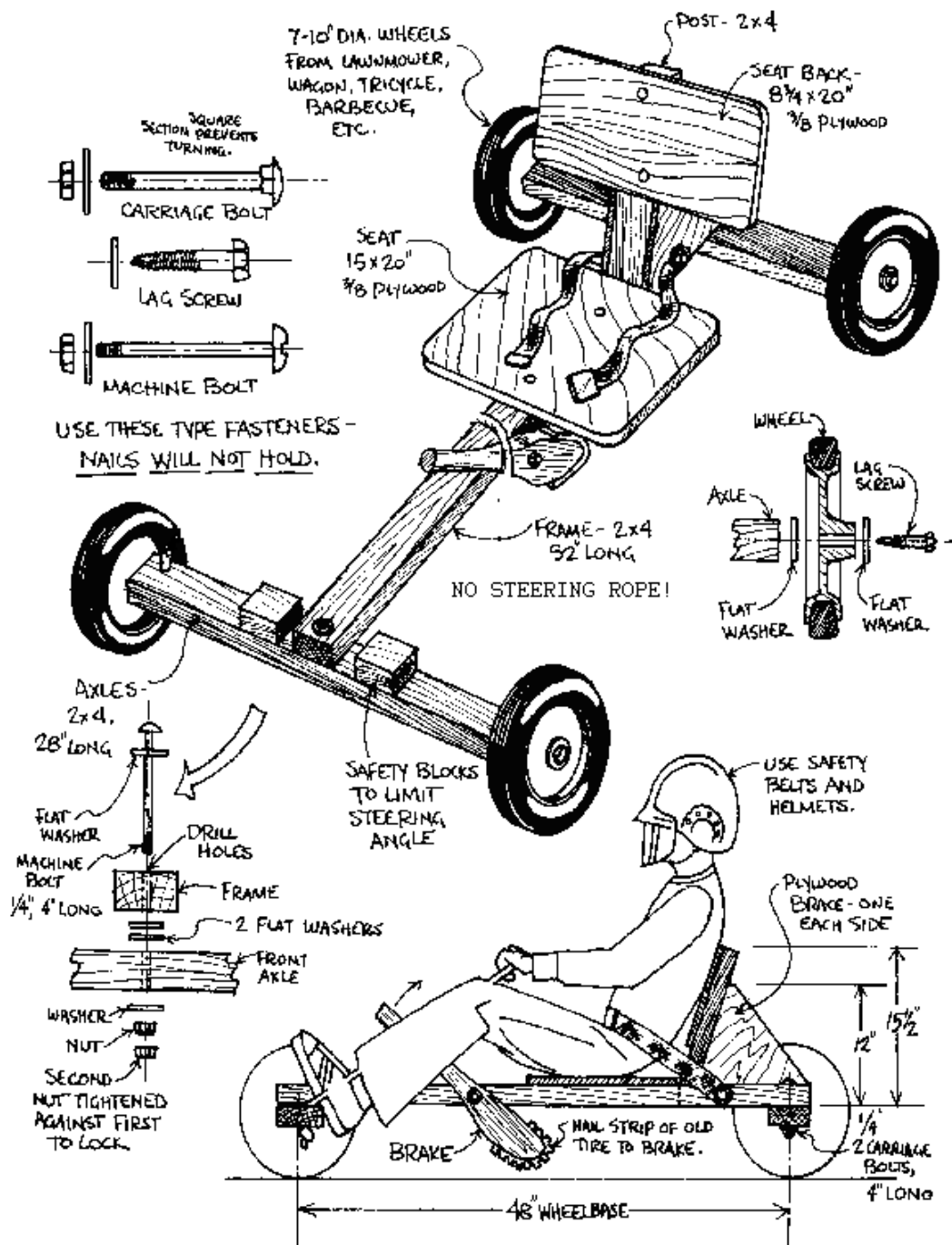

CUBMOBILE SPECS AND PARTS

Suggestions for improved performance and convenience:

1. Use an odd number of bolts where 2x4s meet to avoid splitting the wood during minor impacts, e.g. with the curb.
2. Make the gap between the main 2x4 and the steering restriction blocks very small (1/8 inch or less) to avoid wild steering.
3. Take the car out for a test ride before the race and in time to correct any problems.
4. Use the largest diameter wheels (10") allowed for best speed. Also, wheels less than about 5" in diameter (the minimum allowed) will not climb curbs and will result in a more a severe impact if the driver strikes the curb.
5. Install a tow system to haul your cubmobile back uphill after each race (e.g. attach an eye bolt near the front of the car and pull the car with a rope bearing a knot at one end that is larger than the eye bolt hole).
6. Build a guide that will allow you to drill axle holes that are perfectly aligned.
7. Install safe handles for the driver to hold on to, or install the brake so that the driver is steadied by holding the brake handle.
8. Seat belts can often be purchased cheaply at auto parts stores and bolted on. Inexpensive wheels can be purchased in the lawnmower department of many lumber stores.

Race Rules:

1. More than one driver may use the same car on different races. No more than two drivers per car is recommended, but not strictly enforced. Each driver gets four races.
2. Closed-toe shoes, a helmet, and a seat belt are required of each racer.
3. Cars raced in previous years are acceptable if they conform to current rules.
4. Cars must be inspected and approved by race officials according to the construction rules given.
5. A minimum of four races per car will be provided and the average time of the best three races will be used for deciding awards.
6. Judges decisions are final.
7. A car that crosses the center of the road and strikes or impedes another driver will be disqualified from that race. At the race officials discretion, the impeded car may be given a rerun, but officials are not obligated to do so.
8. If a car stops before the finish line, the driver may briefly lift the car and push to restart it while seat-belted, but no other persons are allowed to help.
9. 10:00 is the registration deadline. All drivers must present a signed registration form by this time or risk non-entry. The cost of entering is FREE. We want your participation!



Eagle District Cubmobile Race

Saturday May 15, 2010, 10:00 AM

(Registration at 9:00 AM)

Driver Registration Form

Cub Scout Name: _____

Pack #: _____

Street Address: _____

City: _____ State: _____ Zip: _____

Home Phone: _____ Parent Alt Phone #: _____

In case of emergency contact: _____ Phone: _____

Relationship to Scout _____

I (We), the parent(s) or guardian(s) of the above named Cub Scout, hereby give my (our) consent for him to participate in the 2010 Eagle District Cubmobile event. I (we) absolve and hold harmless the organization, officers, and volunteers of the Boy Scouts of America, and the City of Luther. I (we) further absolve the race judges and staff of any personal liability resulting out of this event. I (we) understand that this event involves my (our) scout in the racing of a homemade Cubmobile and my (our) son's involvement is strictly my (our) decision and I (we) assume all risks. My (our) son has no medical restrictions that would inhibit him from participating in this event.

Parent or Legal Guardian Signature

Date

Parent or Legal Guardian Signature

Date